

**VILLAGE OF PORT WASHINGTON NORTH**

3 Pleasant Avenue  
Port Washington, New York 11050  
Tel: 516-883-5900 Fax: 516-883-5926  
portwashingtonnorth.org

Date Approved \_\_\_\_\_

Permit # \_\_\_\_\_

Denial Basis \_\_\_\_\_

Date Paid \_\_\_\_\_

Superintendent \_\_\_\_\_

**APPLICATION FOR PUBLIC WORKS PERMIT**

The undersigned does hereby apply for a permit for the following:

Location \_\_\_\_\_

Purpose \_\_\_\_\_

Dumpster	<input type="checkbox"/>	Road Opening	<input type="checkbox"/>
Peddling	<input type="checkbox"/>	Sidewalk, Apron, Curb, Curb Cut	<input type="checkbox"/>
Miscellaneous Public Works	<input type="checkbox"/>	Other	<input type="checkbox"/>

Applicant \_\_\_\_\_ Signature \_\_\_\_\_ Email \_\_\_\_\_

Address \_\_\_\_\_ Phone \_\_\_\_\_

Dumpster application must include:

Location (2 property plans or surveys indicating major structures & proposed location); Dimensions; Provider's Name & Address; Duration; Workers Compensation & \$1 million Liability Insurance; Fee \$50 for 3 days, \$10 each additional day.

Peddling application must include:

Copy of N.Y.S. Driver's License; Current DMV Abstract of Driver's Record; Description of goods/ Services being offered; Name & address of firm/organization sponsoring the peddling; Statement that firm/organization has not been dissolved, enjoined or prohibited from engaging in peddling, including matters relating to or affecting fitness to conduct or method of conducting said activities; \$25 Fee.

Road Opening applications must include:

Two Sketches (showing: location of the work to be done; the length, width & depth of the opening; existing curb cuts; distances from the nearest intersection); Zoning; Workers Compensation & \$500,000 Liability Insurance; Notification to Public Utilities (811); \$10,000 License or Permit Bond; \$250 Fee for 4 months, \$10 each day thereafter.

Sidewalk, Apron, Curb & Curb Cut applications must include:

Two Sketches (showing: location of the work to be done; the length, width & depth of the opening; existing curb cuts; distances from the nearest intersection); Zoning; Workers Compensation & \$500,000 Liability Insurance; Notification to Public Utilities (811); \$10,000 License or Permit Bond; \$100 Fee.

# Village of Port Washington North

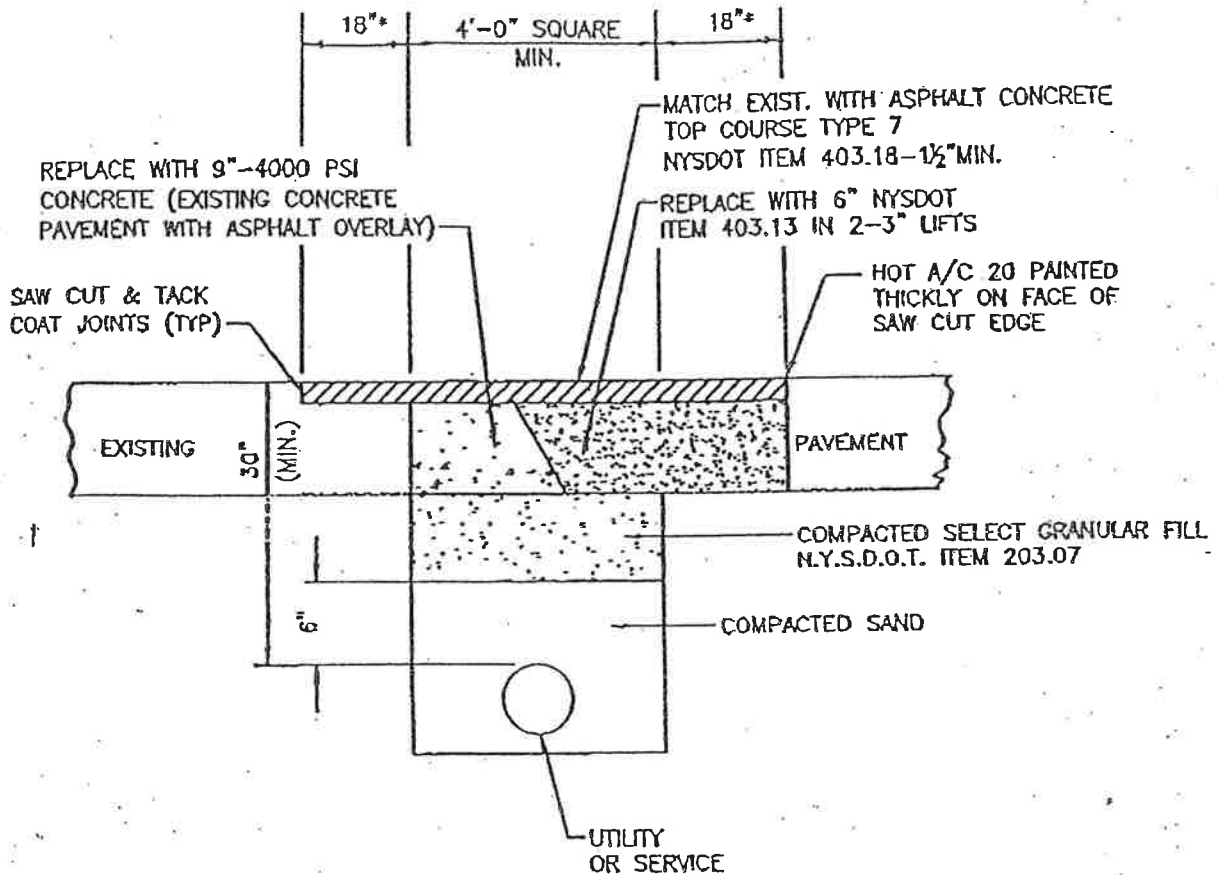

\* 18" CUT BACK, OR TO CURB WHEN CURB IS LESS THAN 4" FROM EDGE OF PATCH

## PAVEMENT & EXCAVATION RESTORATION DETAIL

N.T.S.

### NOTES:

EXCAVATION SHALL BE BACKFILLED AND COMPACTED IN 6" LIFTS

TEMPORARY PAVEMENT REPLACEMENT WILL BE ALLOWED ONLY WHEN ASPHALT PLANTS ARE NOT IN OPERATION. WHEN TEMP. PAVEMENT IS USED, CONTRACTOR SHALL BE RESPONSIBLE FOR MAINTAINANCE AND UPKEEP OF SAID PATCH UNTIL PERMANENT PATCH IS INSTALLED.

UPON THE AVAILABILITY OF ASPHALT, THE CONTRACTOR SHALL EXCAVATE TO THE ORDERED DEPTH AND REPLACE WITH THE REQUIRED MATERIALS TO THE LIMITS AND SPECIFICATIONS AS SHOWN IN THE DETAIL.

ROAD OPENINGS SHALL BE RESTORED WITH PAVEMENT MEETING THE VILLAGES SPECIFICATIONS, FROM THE CURB TO THE OPPOSITE CURB.

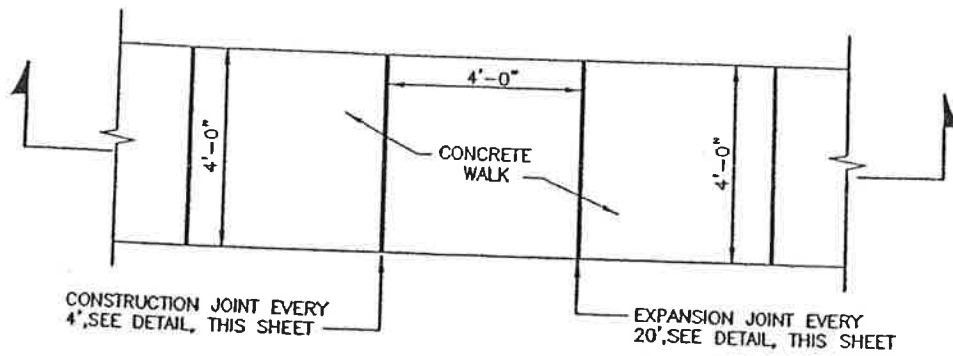

PLAN

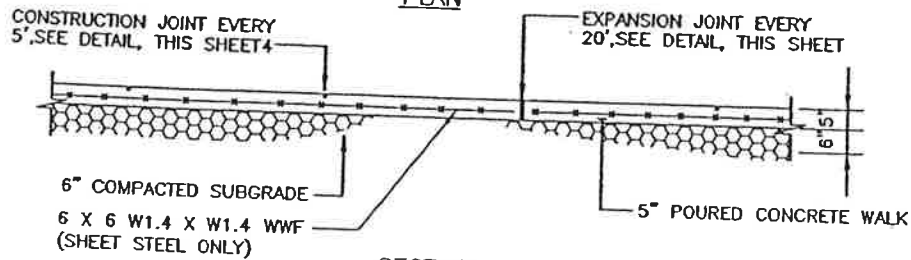

SECTION

CONCRETE SIDEWALK DETAIL

N.T.S.

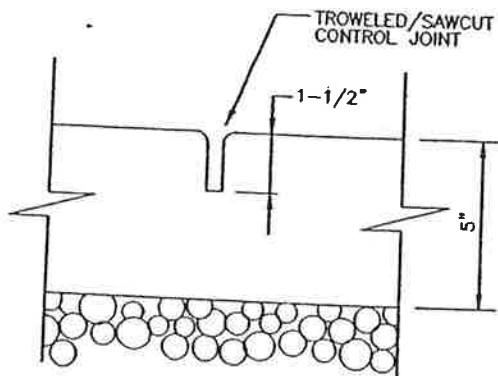

CONSTRUCTION CONTROL JOINT DETAIL

N.T.S.

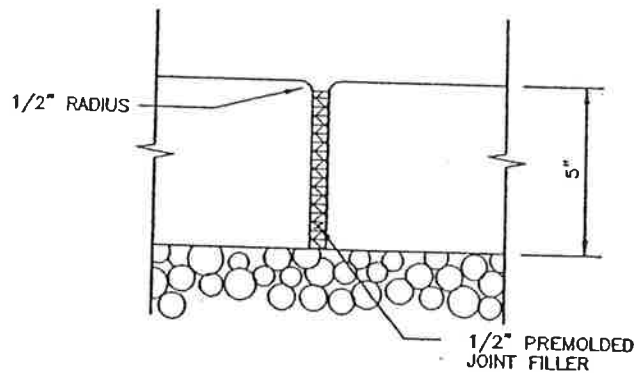

EXPANSION JOINT DETAIL

N.T.S.



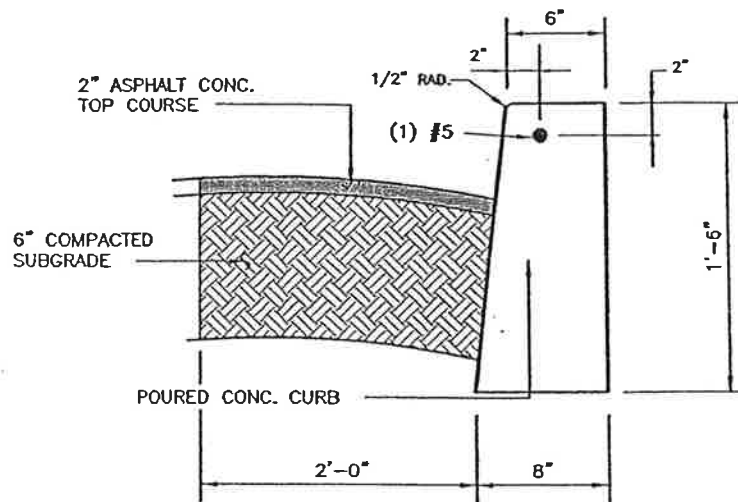

### CONCRETE CURB DETAIL

N.T.S.

1. NEW CURB SHALL HAVE A SMOOTH TRANSITION WITH EXISTING CURB
2. CURB REVEAL SHALL BE 6" EXCEPT AT DROP-CURB AND/OR HANDICAP RAMP.  
(SEE RESPECTIVE DETAILS)
3. 1/2" PRE MOLDED EXPANSION JOINT FILLER SHALL BE INSTALLED 20' O.C.



Dvirka and Bartilucci  
Consulting Engineers  
A Division of William F. Cosulich Associates, P.C.

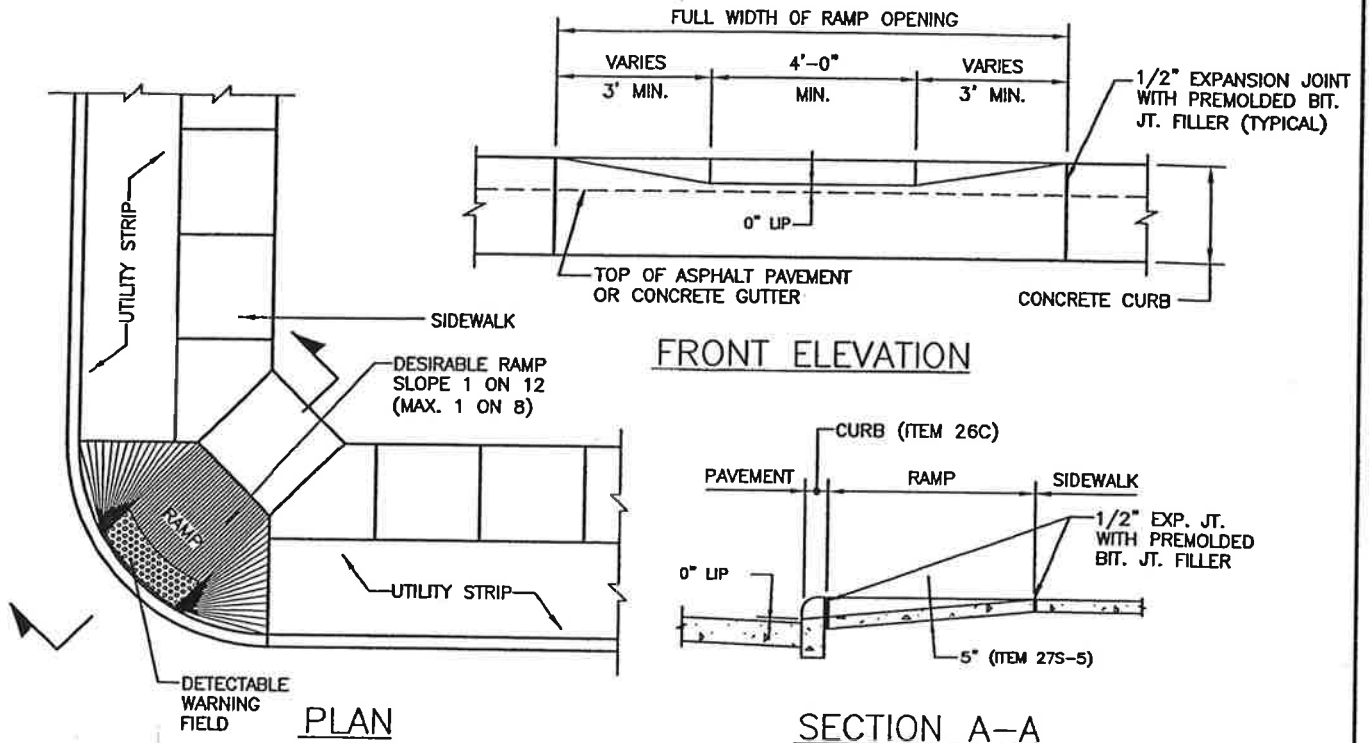

**HANDICAP RAMP NOTES:**

1. CURB CUT RAMPS TYPE AND LOCATION ARE TO BE AS SHOWN ON THE PLANS OR AS DIRECTED BY THE ENGINEER.
2. SURFACE TEXTURE OF THE RAMP SHALL BE TRANSVERSELY DEEP GROOVED 1/2" WIDE x 1/4" DEEP ON 1" CENTERS.
3. THE NORMAL PAVEMENT EDGE PROFILE SHALL BE MAINTAINED THROUGH THE AREA OF THE RAMP.
4. WHEN AN INTERSECTION CONTAINS PEDESTRIAN ACTIVATED SIGNALS, MAKE PROVISIONS FOR A PERSON IN A WHEELCHAIR TO ACTIVATE THE SIGNAL WITHOUT STOPPING ON RAMP.
5. STOP LINES ARE TO BE PROVIDED IN ADVANCE OF WHEELCHAIR RAMPS.
6. WHERE FEASIBLE PROVIDE FOR DRAINAGE PICK UPS IMMEDIATELY UP STREAM FROM THE RAMP.

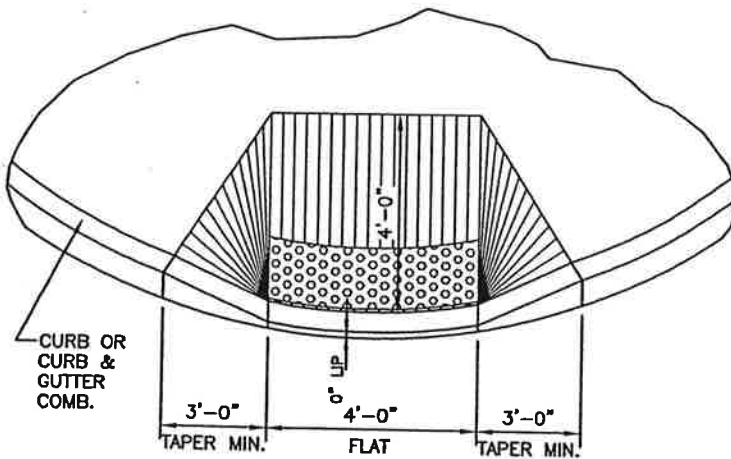

**HANDICAP RAMP**

CENTERED IN CORNER QUADRANT  
(FOR ALL CORNERS WITHOUT OBSTRUCTIONS)  
N.T.S.



Dvirka and Bartilucci  
Consulting Engineers  
A Division of William F. Cosulich Associates, P.C.

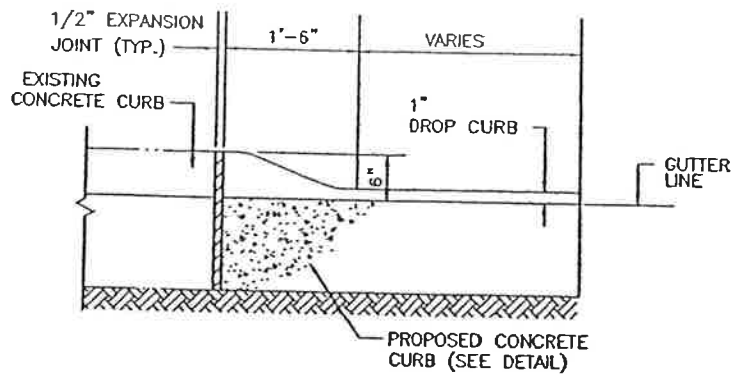

HALF SECTION  
DRIVEWAY CURB CUT  
N.T.S.

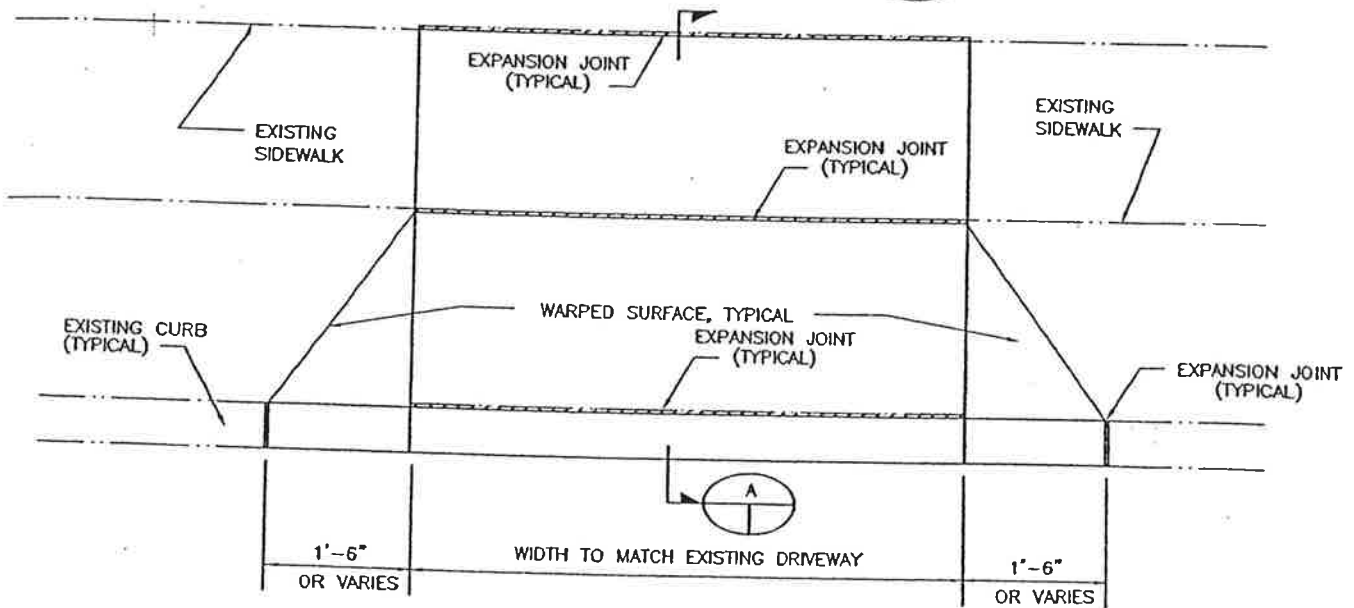
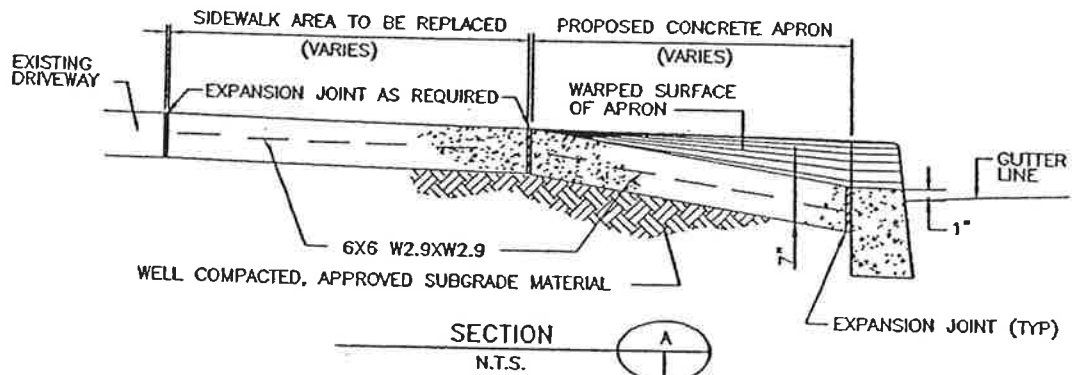

DETAILS OF DRIVEWAY APRON  
PAYMENT FOR CURB UNDER ITEM 26C



Dvirka and Bartilucci  
Consulting Engineers  
A Division of William F. Cosulich Associates, P.C.